

US Hallway COM2-24

Occupancy Sensor



The US Hallway COM2-24 is a low voltage Ultrasonic Technology Occupancy Sensor (40 kHz) that utilizes STEINEL's state of the art ultrasonic signal processing to provide superior stable volumetric bidirectional detection for independent control of both lighting and HVAC. Lighting is controlled in relation to both the presence of motion and ambient light levels. The HVAC output (isolated normally open and normally closed dry contacts) are signaled in relation to only the presence of motion. The unique linear bidirectional coverage pattern is engineered specifically for hallways and applications requiring a true volumetric bidirectional linear pattern of detection. This is an ideal hallway sensor for design and retrofit applications. Operational choices of manual on or auto on with either momentary or maintained switch options. Included "force off" light level feature provides the option to turn lights off when sufficient daylight is present for additional energy savings. The convenient "COM-Link" feature enables multiple sensors to link together via the communication link for peer to peer grouping achieving expanded detection zones with control set up functions set at only one primary sensor for the entire group. Mounting options provide for 4" Square box, 4" Octagon box, Round 3.0 Mud-Ring or directly to the ceiling with quick mount spring tabs. The available service and user wireless remotes provide simplified commissioning and occupant convenience.

The Control PRO group of presence detectors are available in multiple presence detection technologies for the control of heating, ventilation and air-conditioning as well as lighting (as in the COM2-24 versions) and optional 1-10 volt dimming and daylighting options (in the DIM-24 versions).

Applications

The typical best practice applications for the US Hallway sensors are: Hallways, tunnel walkways, sky walks, etc.

Project Name:

Location:



US Hallway COM2-24 Specifications

| | |
|--|--|
| Item No. | 64560 US Hallway COM2-24 |
| Accessories | 65300 RC 3 service remote 65320 RC 4 user remote 65330 WGC wire guard cage |
| Voltage | 18-24 VDC/VAC (34 mA) 50/60 Hz |
| Load Rating | control output - 1 A @ 30 VAC/VDC HVAC dry contacts - 1 A @ 30 VAC/VDC |
| Sensing Technology | ultrasonic (40 kHz) |
| Time Delay Setting | control output - 30 sec. - 30 min. pulse mode (approx. 2 sec. 'ON' 8 sec. 'OFF') IQ mode (automatic adjustment to the usage profile) HVAC dry contacts: 0 sec. - 10 min. switch 'ON' delay 1 min. - 2 hrs. stay 'ON' time auto-HVAC mode |
| Light Level Setting | 10 - 1000 lux / 1 - 100 fc |
| Environment | IP20 rated, 0° C to +40° C / 32° F to 104° F |
| Ultrasonic Detection Zones: (Coverage at 2.5 m / 9 ft) | max. of 2 x 20 m (40 sq.m.) min. of 2 x 5 m (10 sq.m.) max. of 6.5 x 65 ft (422.5 sq.ft.) min. of 6.5 x 20 ft (130 sq.ft.) |
| Dimensions | 4.72 x 4.72 x 2.87 in, 120 x 120 x 73 mm (LxWxD) |
| Warranty | 5 years |
| Certifications | C-UL-US Listed, RoHS compliant UL 2043 Plenum Rated, CA Energy Code compliant |

Key Features:

- Low voltage (18-24 VDC/VAC) sensor for use with a power pack or building automation system
- Independent ON and OFF time settings for the HVAC (NO/NC)
- Ultrasonic (40 kHz) Occupancy Sensor
- Service and user wireless remotes available
- Manual ON mode (MAN) / Automatic mode (AUTO)
- Momentary / Maintained switch option
- 'ON' only / 'ON' & 'OFF' manual switching
- Light level feature turns lights off with sufficient daylight
- IQ Mode dynamically adjusts the 'ON' time delay by learning individual room occupancy
- Auto-HVAC mode reduces presence detection sensitivity and requires additional detection verification before signaling the HVAC output.



Ultrasonic



6.5 x 65 Ft Max



1 - 100 fc



18 - 24 VDC/VAC & HVAC



30 Sec - 30 Min

www.steinell.net

US Hallway COM2-24

Occupancy Sensor



Wi

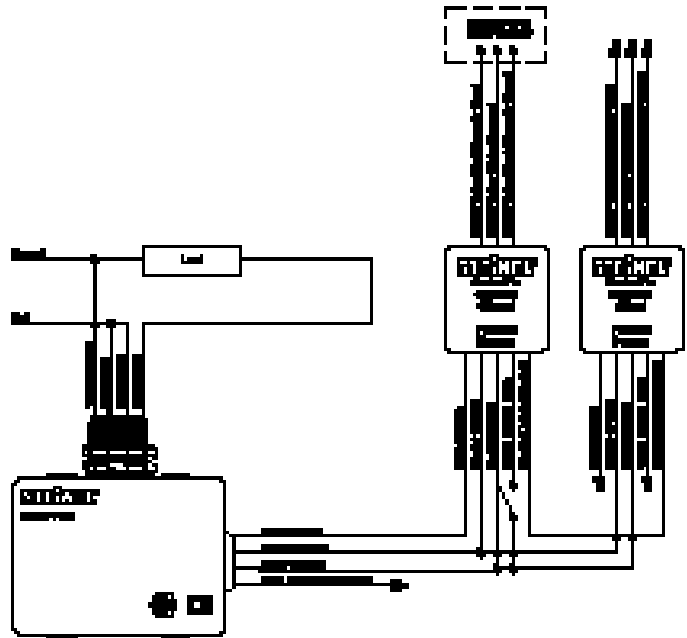
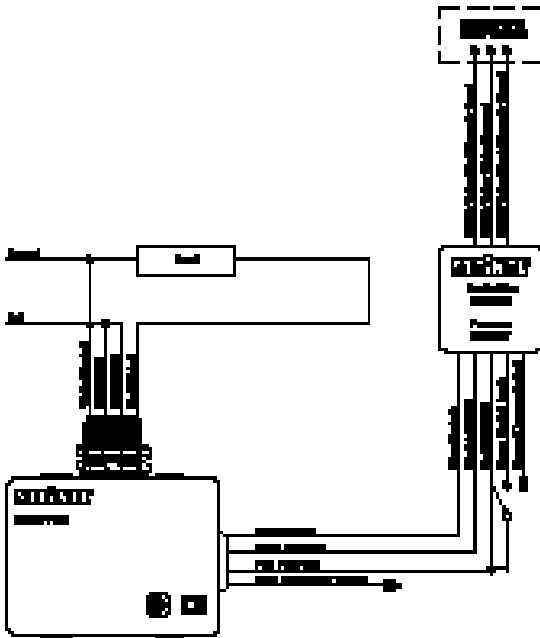

Settings

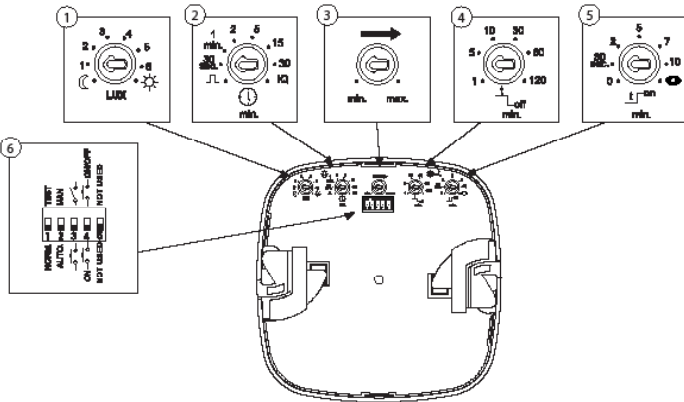

- DIP 1 - Normal mode / Test mode (NORM / TEST)
- DIP 2 - Manual ON mode (MAN) / Automatic mode (AUTO)
- DIP 3 - Momentary / Maintained switch option
- DIP 4 - 'ON' only / 'ON' & 'OFF' manual switching
- DIP 5 - Not used

- 1 - Light level setting
- 2 - Occupancy time delay setting
- 3 - Reach setting
- 4 - HVAC stay-'ON' time
- 5 - HVAC switch-'ON' delay
- 6 - Sensor DIP switch settings

Coverage

Shown coverage diagram at 9 ft mounting height. Ultrasonic signal can be increased by hard surfaces and decreased by soft surfaces.

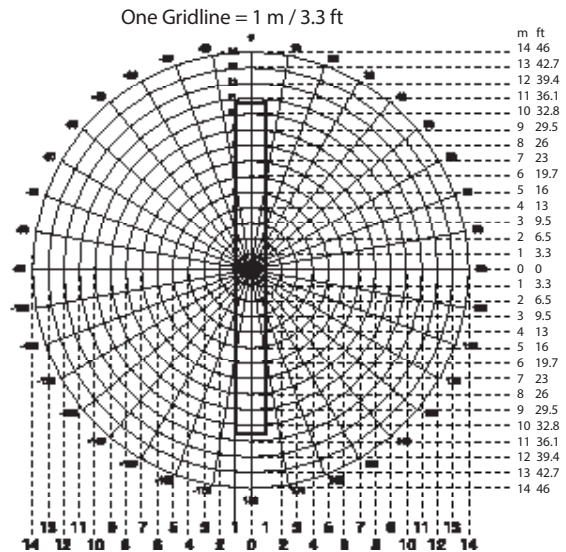

Mounting

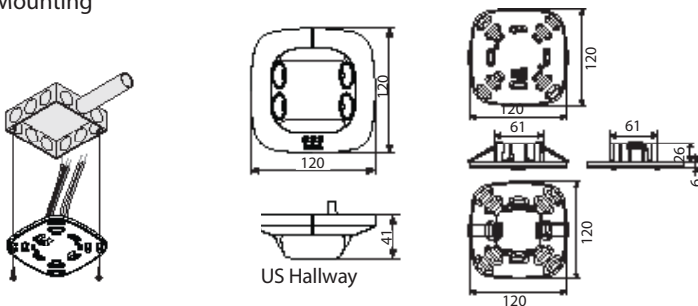

Mounts to a 4" Square box, 4" Octagon box or Round 3.0 Mud-Ring

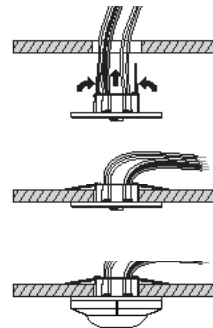

with quick mount spring tabs

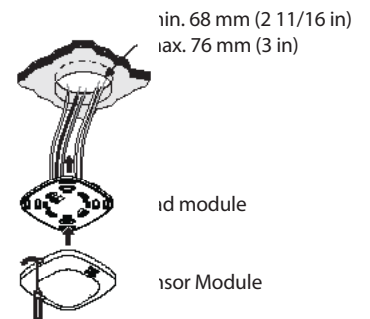

id module

isor Module